

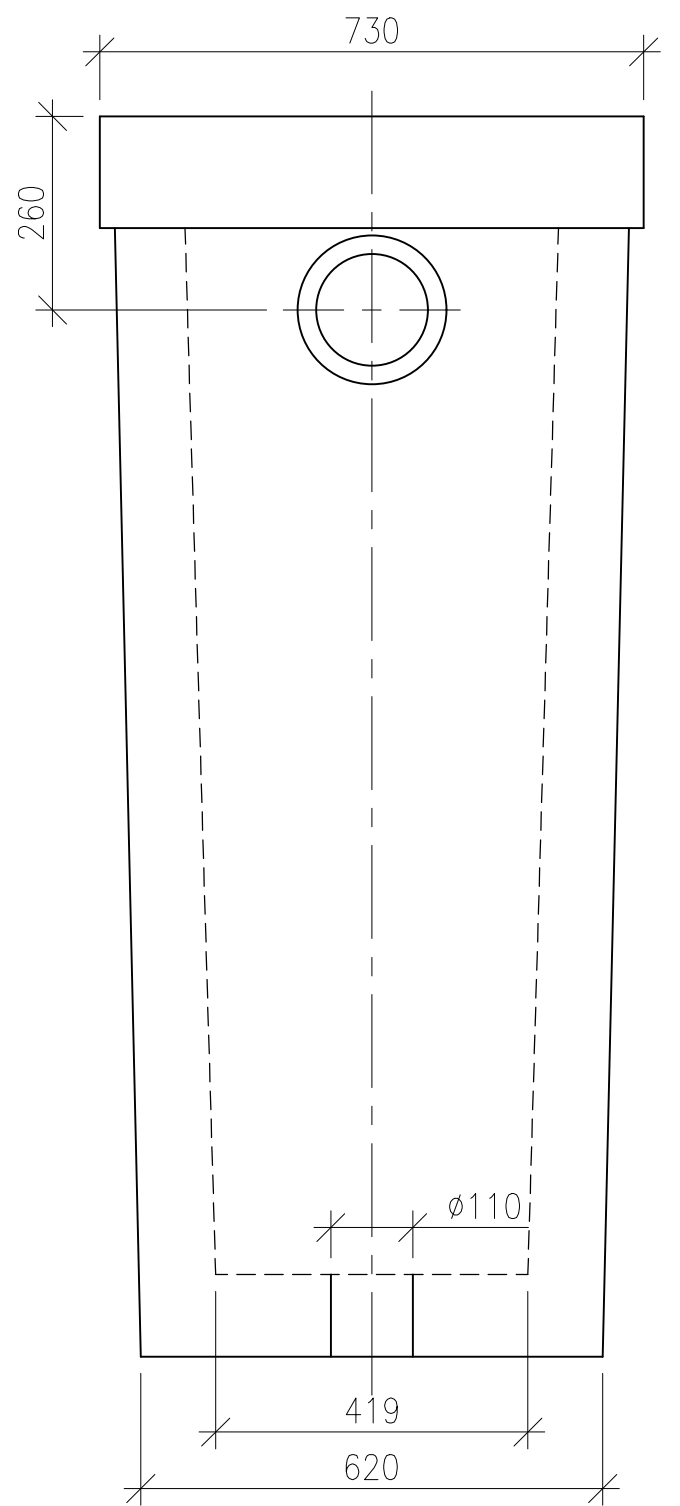

**ELEVATION
SECTION - AA**

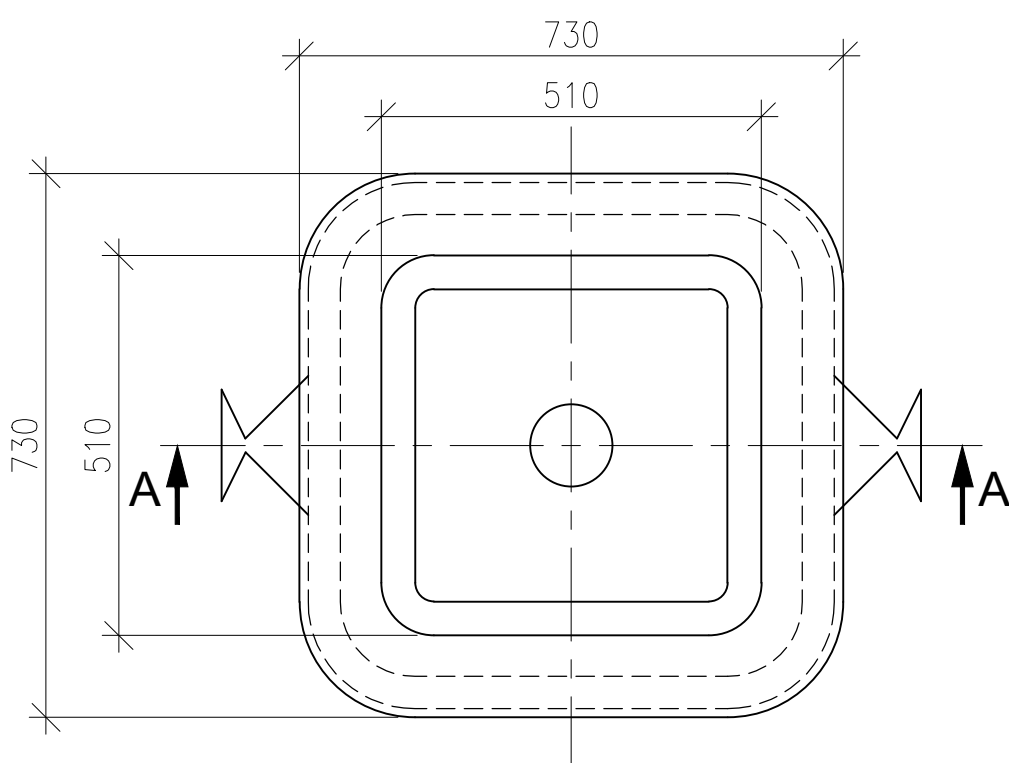

SIDE VIEW



| | | | | |
|--|--------------------------|---|---------------------------|---------------------------|
| TYPE :- SQUARE | MOULD SIZE | | APPROVED BY : AKM | |
| DRG. NO LSL/MLD/009 | INCHES 16.5 X 20 X 65 | MM 420 X 510 X 1650 | MOULD WEIGHT : 2320 KG | INGOT WEIGHT : 2550 KG |
|  LAXCON STEELS LIMITED | | THIS DRAWING WAS ORIGINATED BY AND IS THE EXCLUSIVE PROPERTY OF LAXCON STEELS LTD. IT IS FURNISHED FOR RECIPIENTS INFORMATION ONLY AND IS NOT AN AUTHORISATION OR LICENSE TO MAKE CONSTRUCTION OR COPIES THEREOF TO FURNISH THIS INFORMATION TO OTHERS. | | |